

SPTD

Dimensions SPTD

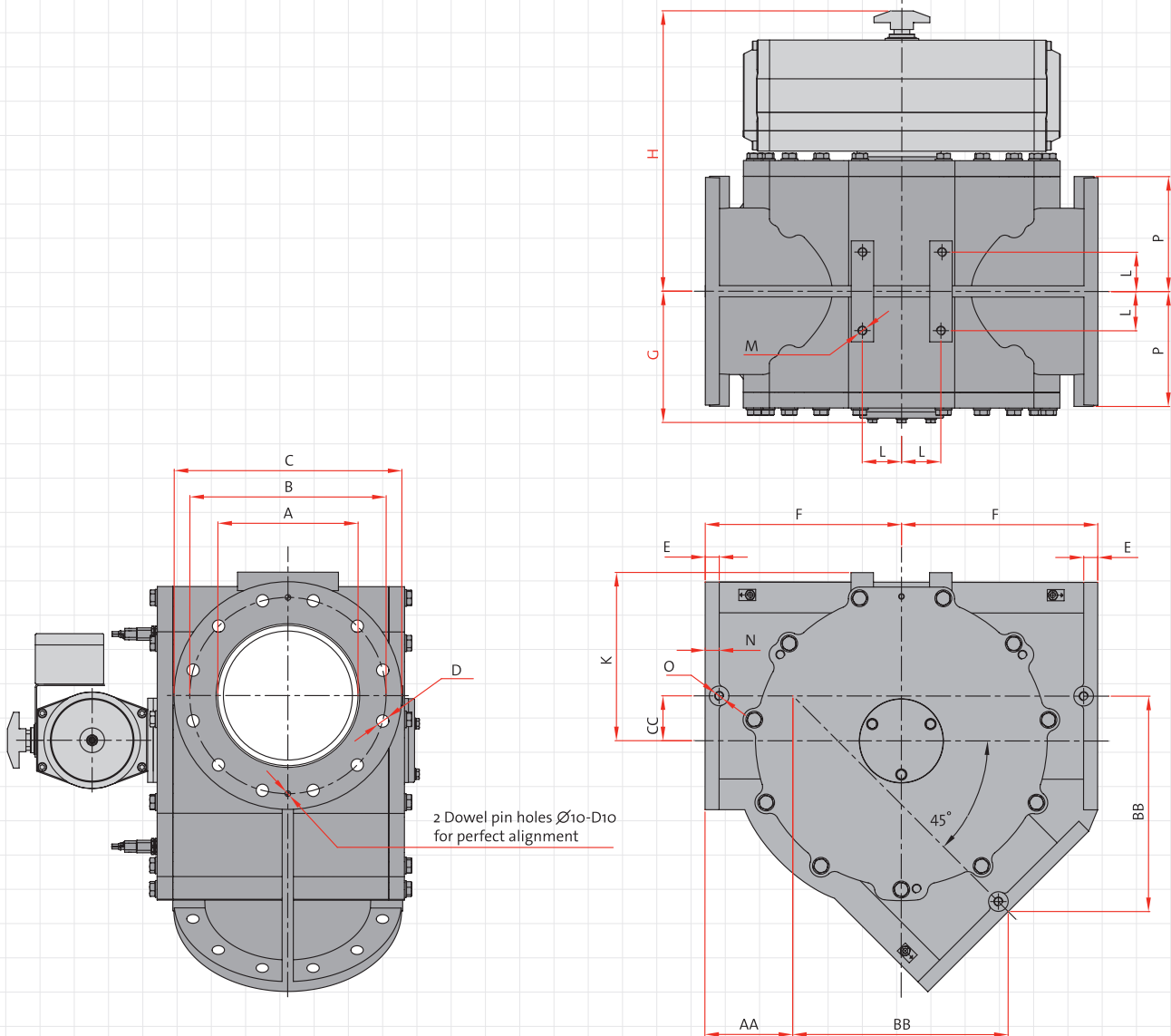

Type SPTD	ØA	DIN			ANSI			E	F	G	H	K	L	M	N	O	P	AA	BB	CC
		ØB	D	ØC	ØB	D	D													
150	150	240	8xØ22	285	241,3	8xØ22,2	20	260	180	390	195	50	M16x24	20	M16x24	145	151	261	45	
162*	162																			
200	200	295	8xØ22	343	298,4	8xØ22,2	25	300	205	435	240	50	M16x24	25	M16x24	175	155	315	60	
213*	213																			
250	250	350	12xØ22	406	361,9	12xØ25,4	25	350	235	500	300	70	M16x24	25	M16x24	205	156	384	80	
267*	267																			
300	300	400	12xØ22	483	431,8	12xØ25,4	25	400	260	525	360	70	M16x24	25	M16x24	245	170	445	95	
318*	318																			
350		available on request																		
400		available on request																		

* Inside diameter of pipe

DMN
WESTINGHOUSE

Technical modifications are possible, dimensions in mm | Technische wijzigingen voorbehouden, maten in mm |
 Technische Änderungen vorbehalten, Maße in mm | Changements d'exécutions techniques possible, dimensions en mm |
 Son posibles variaciones técnicas, dimensiones en mm | Sono possibili variazioni tecniche, dimensioni in mm |
 Możliwe są modyfikacje techniczne, wymiary w mm | Сохраняется право на внесение технических изменений, размеры в мм

www.dmnwestinghouse.com